

Driving innovation

IONIQ hybrid



Experience the future of mobility in your daily life.

Welcome to the future.

Leadership in the new era of zero emissions mobility is being realized through our development of innovative green technologies that are continually raising the industry standard for fuel efficiency.

發揮驅動者地位，帶領市場逐步邁向零排放的新紀元。
透過現代汽車研發的綠色技術，不斷提高燃油效率，譜出業界新標準。







What a pleasant surprise.

A pioneering design that marries form with function, IONIQ hybrid's striking, coupé-style silhouette certainly creates a strong first impression. But looking beyond the sleek aerodynamics you will discover subtle design details that enhance every aspect of driving dynamics and efficiency.

IONIQ Hybrid 轎跑車身線條，結合實用與外觀於一體，革新設計突顯車身輪廓，讓人留下深刻印象。卓越的風阻系數，加上貼心的設計細節，令駕駛感及效率有增無減。

Aerodynamic Cd
風阻系數

0.24

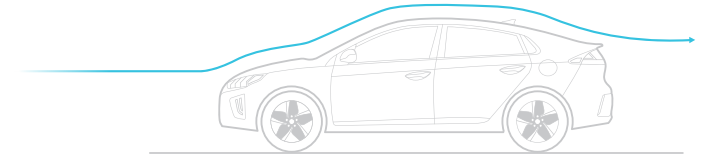

Radiator grille 前鬼面罩

The new mesh-type grille adds a strong 3D effect for emphasis and maximum visual impact while serving its intended function.

新網狀型鬼面罩加強立體感，3D設計大大增強了視覺效果。



LED rear combination lamps LED 尾組合燈

Not only gorgeous, the new chevron pattern with its wraparound setup is simple and certain to get immediate attention.

時尚V形尾燈，設計簡單而華麗，令新一代 IONIQ 更能鶴立雞群。



Rear bumper 尾防撞桿

Fresh, new colors for the bottom insert and lower lip amplify the two-tone effect to make the bumper look sportier than ever.

防撞桿底部採用鮮明顏色，令反差色效更明顯，跑車氣息更強烈。



Elegance and peace of mind.

With its disciplined focus on layout simplicity and good ergonomics, the interior advances the evolution of trendsetting design. As forward-thinking as the exterior, the interior abounds with fine touches that bring all the key elements to life in fluid, elegant style. Every detail is precisely designed around the philosophy of clean simplicity for a calming, soothing effect on the senses.

現代汽車執著於車廂品味設計及行車駕駛舒適，繼而不斷改進車款的內外設計。車身外觀前衛進取，車廂內飾精緻細膩，讓優雅風格走入生活。每個細節匠心獨運，按著精確實用而簡約利落的理念，設計出讓人感到最舒服平和的組合。

Supervision cluster with 7" colour LCD 7吋LCD電子儀表板

All vital car system information is presented with astounding legibility and colourful graphic format that only Supervision technology can deliver.

所有重要的行車資訊都盡收於電子儀表板內，助您於路上運籌帷幄。



8-inch display audio 8吋資訊娛樂系統

IONIQ's nerve center does more than keep you on course. It offers total smartphone connectivity through a simple-to-use touchscreen interface.

IONIQ 的娛樂系統操作簡單，透過輕觸屏幕，助您享受娛樂的同時保持正常行車狀態。



D-cut steering wheel

D 型軟盤

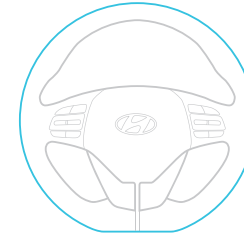

Touchscreen air conditioning controller 輕觸式冷氣調控

Just as you would expect of Hyundai's high-tech flagship, the touchscreen AC controller is a cut above the rest and looks very cool indeed.

現代高科技貼心設計一如既往，從未令人失望，以輕觸屏幕控制車內溫度，簡約的時尚就是如此。





Driving freedom with no compromises.

When it comes to driving, I'm cautious and so is my IONIQ. It can spot problems much quicker than I can. Like my own personal bodyguard, IONIQ's Advanced Driver Assist Systems have my back. Features like Lane Keeping Assist are on the constant lookout for signs of potential danger and reducing risk. And that makes me feel safer than ever behind the wheel.

駕駛謹慎——為每個駕駛者的首要態度，IONIQ 亦是如此。新一代 IONIQ 駕駛輔助系統能快速地發現問題，於道路上一直監測潛在的危險跡象並從而降低風險。一路上都伴隨駕駛者，成為最安全的並肩同路人。



Lane Keeping Assist (LKA) 車道保持輔助系統 (LKA)

LKA keeps the car centered within the lane markers using a front view camera. Should the vehicle drift out of its intended lane path, LKA sets off a visual and sound alarm and automatically corrects the steering angle thereby preventing unintentional lane departure.

透過前鏡頭檢測行車線，協助防止車輛偏離行車線。當出現偏離行車線的狀況時，系統會發出警示，並自動輔助車輛返回行車線，以防止意外發生。



7-airbag system

7 安全氣袋系統

Should the unexpected ever happen, seven airbags provide the ultimate protection. Up front, a pair of front airbags and another pair of side airbags for thorax protection with the driver getting added protection from a knee airbag. Full-length curtain airbags defend against side collisions.

前排的一對安全氣袋和一對側安全氣袋，用於保護駕駛者及前排乘客的胸部，及防止側面碰撞，而膝部安全氣袋則為您的腳部提供了額外的保護。不幸遇上意外時，安全氣袋系統成為了最佳保護網，將撞擊力減低。

Front Collision Avoidance Assist (FCA)

自動緊急煞車系統 (FCA)

Front view camera and front radar work in tandem to warn of an imminent collision with another vehicle or pedestrian and if necessary, FCA will automatically apply emergency braking to prevent a collision.

利用前鏡頭和雷達，於安全距離下提示駕駛者前方車輛或物件；並在必要時進行緊急煞停以防止碰撞。



Smart Cruise Control with Stop & Go (SCC w / S&G)

智能定速巡航功能 (SCC)

The smart function does more than just maintain the preset speed: SCC automatically maintains a safe distance from the car ahead by using a combination of throttle and brake intervention. SCC will automatically deactivate below 10km/h.

系統記錄及預設駕駛者的行車速度，亦可自動保持與前車的距離，或停或行，均無需由駕駛者使用油門或制動控制。而此系統將在10km/h以下自動停用。





Kappa 1.6L Atkinson-cycle GDi engine
1.6L 公升電油引擎

Displacement_1,580cc 排氣量

Maximum torque_15.0kg-m/4,000rpm 最大扭矩

Valve system_Dual CVT 雙連桿可變引擎活瓣正時

Maximum power_100PS/5,700rpm 最大馬力

Two hearts, one beat.

The epitome of forward-thinking motoring, the 1.6-litre GDi direct-injection petrol engine is intelligently engineered to work in unison with the electric motor to deliver maximum power and optimal fuel economy. Full torque is instantly available resulting in silk-smooth acceleration and a truly agile driving experience that surpasses all other cars in its class.

前瞻性駕駛的縮影是1.6升GDi直噴汽油引擎經過智能化設計，可以與電動摩打協同工作，以提供最大的功率和最佳燃油效益。由平滑加速至敏捷駕駛體驗，遠遠超越同類型車款。

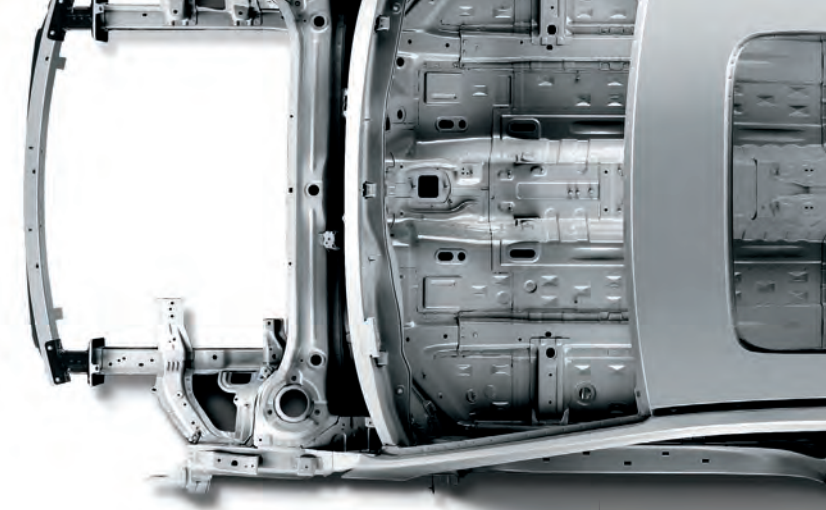

Advanced high-strength steels 高鋼性鋼材車架

The usage of advanced high-strength steel alloys has been expanded to 53 percent of the body structure. To attain unprecedented levels of structural rigidity, critical components were fabricated using advanced hot stamping technology.

採用沖壓技術將鋼材加熱至最高結構剛度，成就出高達53%的高強度鋼合金。

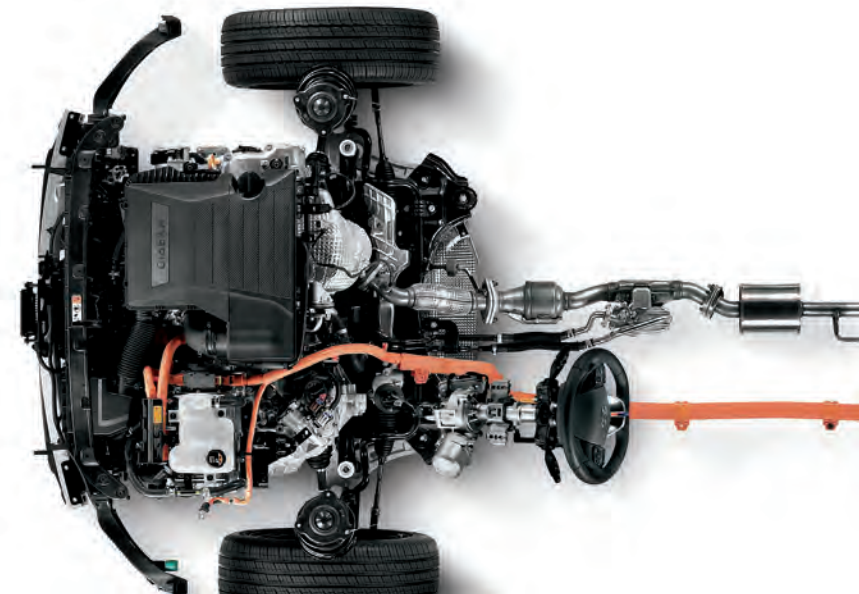



Low center of gravity 低重心設計

By mounting the battery under the seats, IONIQ is able to attain an exceptionally low center of gravity. This greatly enhances agility and helps make IONIQ so much fun to drive.

IONIQ 為使車身獲得極低的重心，將電池安裝在座椅下，既可大大提高了敏捷度，亦令增加了駕駛之樂。

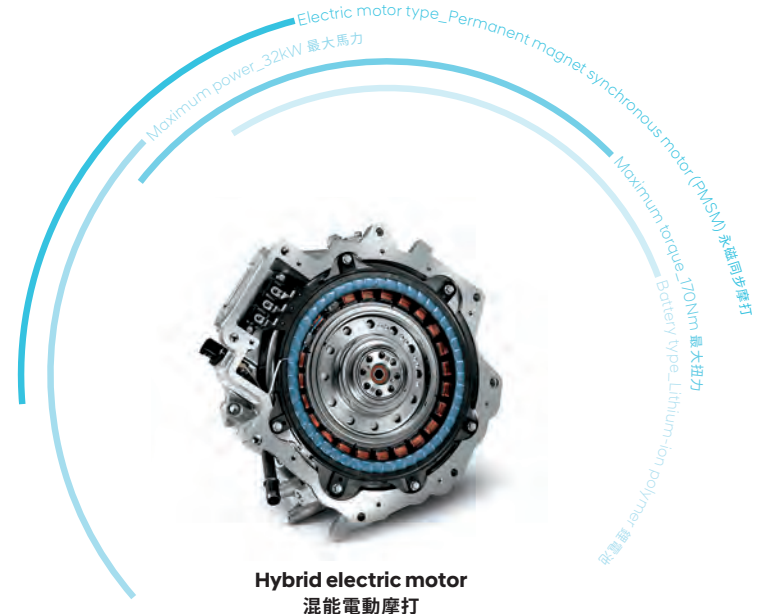
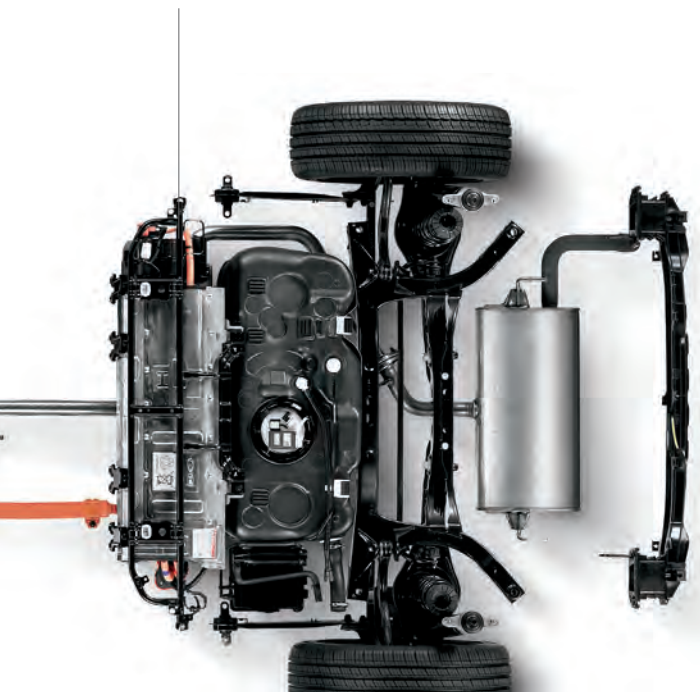

Predictive energy management 能量管理系統

The battery management system optimizes energy storage by recovering braking energy to help recharge the batteries and by continuously collecting and analyzing data on your travel routes and driving habits. Advanced algorithms are employed to switch seamlessly between pure electric drive, pure gasoline propulsion or combined mode as battery reserve power and driving conditions permit.

電池管理系統通過回收制動能量來優化能量存儲，以極大化電池充電量，另外，系統會收集及分析您的行駛路線上的數據，演化成您的駕駛習慣。採用先進的計算方法在純電動和引擎之間無縫切換，在電池備用功率和行駛條件允許的情況下，採用純電動、純引擎或混合模式。

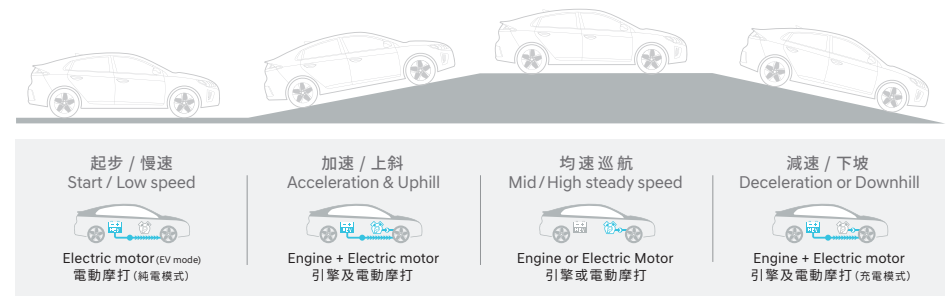



Packages 配備

The GLS model with optional equipment is shown here.



LED DRL
LED 日行燈



LED headlamps
LED 頭燈



Parking distance warning (front)
前泊車感應器



Front safety power window
前安全電動門窗



Power sunroof
電動天窗



Chrome door scuffs
電鍍門邊腳踏



Rear spoiler
尾定風翼



Synthetic leather-appointed cluster
人造皮儀表板裝飾



Mood lamp
氣氛燈



Paddle shifters
軌盤撥片



Front ventilated / heated seats
前排冷暖座椅



USB charging port (center console)
USB 充電座



Seat folding system (6:4 type)
後排 60:40 摺合



Integrated memory system (IMS)
司機席記憶座椅

Exterior colours 車身顏色



Polar White (WAW)



Fluidic Metal (M6T)



Typhoon Silver (T2X)



Phantom Black (NKA)



Electric Shadow (USS)



Fiery Red (PR2)



Intense Blue (YP5)

Interior colours 車廂顏色



Fossil Gray (T9Y)
皮革 - 深灰

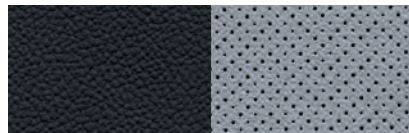

Light Shale Gray (YPK)
皮革 - 淺灰雙色



Red Umber (RNR)
皮革 - 紅色

Wheels 輪圈



17" alloy wheels
17吋合金輪圈

Specifications 規格

ENGINE 引擎

Type 類型	GDi gasoline engine 汽油引擎
Displacement (cc) 排氣量	1,580
Max. power (PS/rpm) 最大馬力	105/5,700
Max. torque (kg·m/rpm) 最大扭力	15.0/4,000

ELECTRIC MOTOR 摩打

Type 類型	Permanent magnet synchronous motor (PMSM) 永磁同步摩打
Max. power (kW) 最大馬力	32
Max. torque (Nm) 最大扭力	170
Battery type 電池類型	Lithium-ion polymer 鋰離子聚合物電池

OTHER

Luggage capacity (liter) 行李箱容量 (升)	Up to roof 一般情況	563
	Rear seats down, up to roof 後排摺合	1,518



Overall width 全闊 1,820



Wheel base 軸距 2,700
Overall length 全長 4,470

Overall height
全高
1,450



Unit: mm 單位

Showroom 陳列室

Shop 1, G/F, YHC Tower, 1B Sheung Yuet Road, Kowloon Bay, Kowloon
九龍九龍灣常悅道1號B恩浩國際中心地下1號舖
Telephone 查詢電話: 3428 8288

Service Centre 維修中心

Kwai Chung 葵涌
1/F, 26-30 Wo Yi Hop Road, Kwai Chung, N.T.
新界葵涌和宜合道26-30號1樓
Telephone 查詢電話: 3421 0640

Tin Shui Wai 天水圍

DD124 & 127 Kiu Tau Wai, Kiu Cheong Road, Tin Shui Wai, Yuen Long, N.T.
(Entrance at Kiu Cheong Road)
新界元朗天水圍橋昌路橋頭圍DD124 & 127 (橋昌路入)
Telephone 查詢電話: 3105 3828

- Hyundai Motor Company and Hyundai Hong Kong Co. Limited reserve the rights to change specifications and equipment without prior notice.
- Some of the equipment illustrated in this catalogue may not be supplied as standard equipment.
- The color plates shown may vary slightly from the actual colours due to limitations of the printing process. Please consult your dealer for full information and availability on colours and trims.
- 5-year unlimited mileage factory warranty.

- 本公司保留改變規格及設備的最終權利，恕不另行通知。
- 本小冊子內容部份設備或非標準配備。
- 基於印刷過程的限制，本小冊子所顯示的顏色與實物顏色或稍有偏差。請向零售商索取內飾和顏色的詳盡資料。
- 原廠保用為五年無限里數。