

# IONIQ

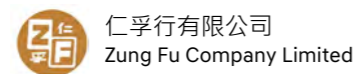

仁孚行有限公司  
Zung Fu Company Limited

陳列室  
Showroom 九龍灣臨樂街 19 號南豐商業中心地下 4D  
G/FI., 4D Nan Fung Commercial Centre, 19 Lam Lok Street, Kowloon Bay

維修中心  
Service Center 新界元朗天水圍, 橋昌路, 橋頭圍 DD124 & 127 (橋昌路入)  
DD124 & 127 Kiu Tau Wai, Kiu Cheong Road, Tin Shui Wai, Yuen Long, N.T. (Entrance at Kiu Cheong Road)

新界葵涌和宜合道 26-30 號 1 樓 (雍雅軒對面)  
1/F, 26-30 Wo Yi Hop Road, Kwai Chung, N.T.

查詢電話 : 3428 8288  
Telephone

查詢電話 : 3105 3828  
Telephone

查詢電話 : 3421 0640  
Telephone



Copyright © 2017 Hyundai Hong Kong Co. Limited. All Rights Reserved.  
www.hyundai.com.hk  
www.facebook.com/HyundaiHK



# IONIQ

## 未來就在這裏 THE FUTURE IS HERE

IONIQ 簡約高雅的設計悅目動人，各種新穎的設備滲透出未來感，而風阻系數極低的 IONIQ 能讓駕駛者與乘客感受寧靜和節能的旅途。

Admire the elegance and simplicity of IONIQ. It looks futuristic and inside, it's brimming with innovative features. IONIQ slices through the wind like no other car aided by its low coefficient of drag that allows driver and passengers to enjoy a whisper quiet ride and great fuel efficiency.

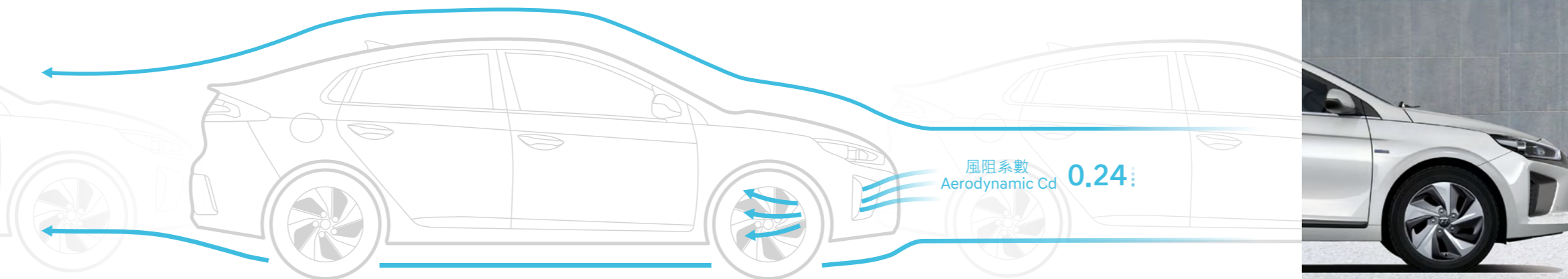

# 完美無瑕融合兩個世界 THE BEST OF BOTH WORLDS

IONIQ 的動力核心由兩部分組成，分別是一個 43.5ps 電動摩打和一個 Kappa 1.6 公升 Atkinson GDi 引擎。IONIQ 可以無縫地在兩者之間轉換動力輸出。

Under IONIQ's hood two hearts beat as one: 43.5ps electric motor and a Kappa 1.6-liter Atkinson GDi engine, IONIQ switches seamlessly between the conventional engine and electric motor.

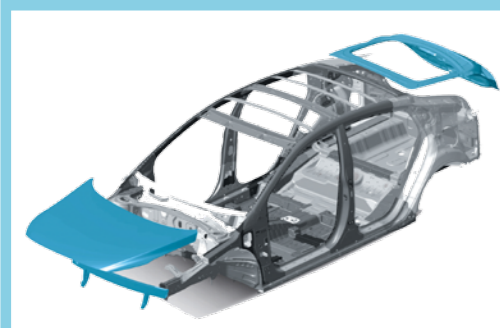

**鋁質車頭蓋及尾門**  
為了提高燃油效益，IONIQ 的車頭蓋及尾門均採用輕量化的鋁材，而安全性絕不能妥協，所以 IONIQ 使用了高熱燙印、高科技聚合及其他革新製作方法以強化重點結構的剛性。

**Aluminum Hood and Liftgate**  
In order to attain the best possible fuel efficiency, IONIQ was put on a diet: IONIQ's hood and liftgate are fabricated from weight-saving aluminum instead of traditional steel. Hot stamping, high-tech adhesives and other innovative manufacturing methods were adopted to reinforce safety critical structures.



**混能電動摩打**  
先進的電池管理系統會主動收集和您的行車路線和駕駛習慣等資訊。系統會計算並作出電動或油動模式之間轉換，而剎車時所產生的能量亦會用作充電。它的最大輸出功率為 43.5ps、最大扭力為 17.3kg-m。

**Hybrid Electric Motor**  
The highly advanced battery management system collects and analyses data on your travel routes, driving style and habits for optimal energy storage. Advanced algorithms are employed to switch seamlessly between electric and gasoline propulsion modes and recover braking energy recharge the batteries. It outputs maximum power 43.5ps and maximum torque 17.3kg-m.



起動 / 低速  
Start/ Low Speed



電動模式  
Electric Motor (EV mode)

加速 / 上坡  
Acceleration & Uphill



油動及電動模式  
Engine + Electric Motor

中 / 高穩定速度  
Mid/High Steady Speed



油動模式  
Engine

減速 / 下坡  
Deceleration or Downhill



充電  
Recharge

IONIQ



**雙離合器傳動系統 (DCT)**  
IONIQ 配備了雙離合器傳動系統 (DCT)，敏捷的轉檔令駕駛更具樂趣。使用 sports 模式可隨意換檔，亦可選擇自動模式享受輕鬆的駕駛樂趣。

**Dual Clutch Transmission (DCT)**  
IONIQ is equipped with a dual clutch transmission that puts the fun into driving. In sports mode, the DCT lets you shift as much as you like. At anytime, you can just switch to automatic mode and enjoy a more relaxing drive.



Kappa 1.6 公升 Atkinson-cycle GDi 引擎  
最大馬力為 105ps/5,700 rpm，最大扭力為 15kgm/4,000rpm。

Kappa 1.6L Atkinson-cycle GDi Engine  
Maximum output is 105ps/5,700 rpm and torque 15kgm/4,000rpm.

## 超高強度鋼

車身結構達 53% 用上超高強度鋼，車體剛度無與倫比。

## Advanced High-strength Steels

The usage of advanced high-strength steel alloys has been expanded to 53% of the body structure to attain unprecedented levels of structural rigidity.

## 低重心設計

將電池放置於座位下的設計，讓 IONIQ 的重心更低，駕駛時更加靈巧。

## Low Center of Gravity

By mounting the battery under the seat, IONIQ is able to attain an exceptionally low center of gravity, greatly enhances agility.

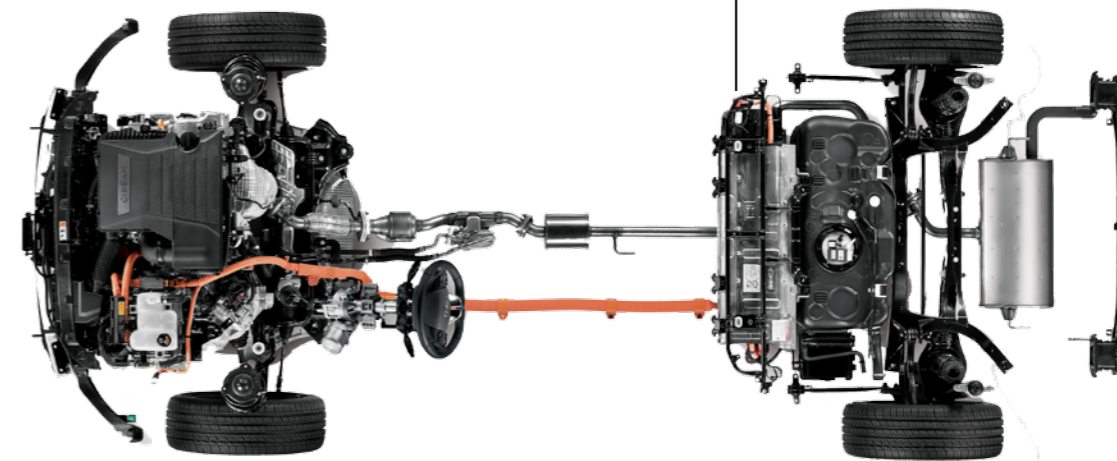
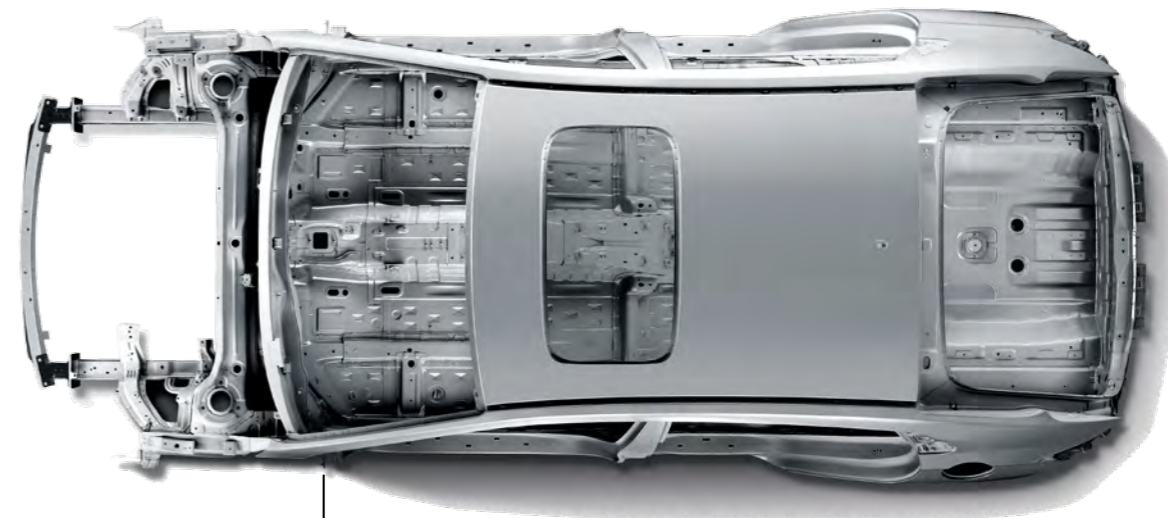

# 引領全新方向 MOVING IN A NEW DIRECTION

IONIQ 混能車的設計正是汽車的未來，獨特的個性及其環保性能（二氧化碳排放：79g/km；綜合油耗：29.4km/L）令它成為大眾之選。同時，IONIQ 的特低排放有助環境更潔淨，享受駕駛樂趣同時亦為地球環境出一分力。

IONIQ hybrid is the future of mobility and has the chance to make a difference with its amazing style, low CO2 emission of 79g/km and combined fuel consumption of 29.4km/L. Act now and make a difference by creating a cleaner, better world. What's more? Driving IONIQ is pure fun.



綜合油耗  
Combined Fuel  
Consumption **29.4km/L**



## LED 尾組合燈

LED 尾組合燈以節省電力為前提照出的最大亮度，在漆黑環境中提供安全保障。

## LED Rear Combination Lamps

Stylish lamps feature LED technology to deliver maximum illumination while drawing a minimal amount of electricity.



## 尾泵把

雙色調的泵把融和運動元素，與車頭外觀設計連貫。

## Rear Bumper

Two-tone bumper has a graphic insert to add a sporty touch and provide continuity with the front end design.

## 家族式鬼面罩

標誌性的六角型鬼面罩配備了電子操控封罩，它們會適時自動合上以減低風阻。

## Radiator Grille

The signature hexagonal grille features computer-controlled flaps that close automatically to improve aerodynamics.



## 後視泊車鏡頭

後視泊車鏡頭協助司機在倒車時看見車尾環境。

## Rear Camera Display (RCD) System

Rear camera display (RCD) system improves the rear-view visibility and assists the driver in detecting objects while reversing.



側鏡飾燈  
Puddle Lamps



電動天窗  
Power Sunroof



日間行車燈  
Daytime Running Light



平底軚環  
D-cut Steering Wheel



防炫光後視鏡  
ECM Rear View Mirror



寬敞行李廂空間  
Spacious Storage Compartment

## 全面滿足車主期望 MAXIMAL SATISFACTION

IONIQ 標準配備包括了 15 吋合金輪圈、日間行車燈、電動天窗、側鏡飾燈等，定義小型房車新標準。而平底軚環設計除了增添運動感，亦讓駕駛者更順暢地進出車廂。

We are raising the standard of small sedan with IONIQ. Its standard specification being equipped with 15" alloy wheel, daytime running light, power sunroof and puddle light. The d-cut steering wheel provides a sporty look but also makes for easier entry and egress.



# 體貼的車廂設計 CONSIDER YOUR NEEDS

IONIQ 的車廂經過精心設計，簡潔典雅而揉合創新點綴，大幅提升駕乘體驗。

IONIQ's interior is a masterpiece of design: elegantly simple and pleasant to the touch but packed with innovative features.



**A** 電動司機座椅  
Power Driver's Seat

**C** 自動冷氣  
Auto A/C

**E** +/- 真皮波棍  
+/- Leather Gear Knob

**G** 前排儲物格  
Center Console

**B** 7吋屏幕錶版  
Supervision Cluster with 7" Color LCD

**D** 可摺疊式座椅 (6:4)  
Seat Folding System (6:4 type)

**F** 後排座椅  
Back Seats

**H** 電鍍門邊  
Chrome Door Scuffs



前後泊車感應器  
Front and Rear Parking Sensor (PAS)

# 安全為駕趣之本 SAFETY IS THE KEY TO DRIVING PLEASURE

將出岔的機會降至最低 · IONIQ 為您多想一步。

IONIQ goes even further to keep you out of trouble.

## 7 安全氣袋系統

7 安全氣袋系統包含了兩個前座氣袋、一個司機腿部氣袋、兩個前座側面氣袋和兩個簾式氣袋。在發生碰撞時妥善保護乘客及司機。

## 7-Airbag System

There is no pleasant journey without a complete protection thanks to the 7-airbags: a pair of front and side airbags with knee airbag for driver along with full-length curtain airbags to defend against side collisions.



## 車身顏色 EXTERIOR COLORS



極緻白 Polar White (WAW)



鉑金銀 Platinum Silver (T8S)

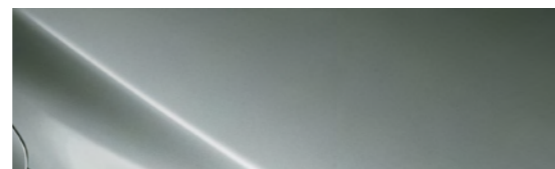

極光銀 Aurora Silver (TS7)

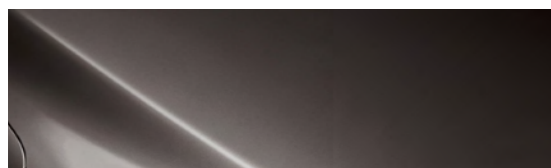

柔和啡 Demitasse Brown (RB4)



鋼鐵灰 Iron Gray (YT3)



幻影黑 Phantom Black (NKA)



海洋藍 Marina Blue (N4B)



鳳凰橙 Phoenix Orange (RY9)

## 車廂顏色 INTERIOR COLORS

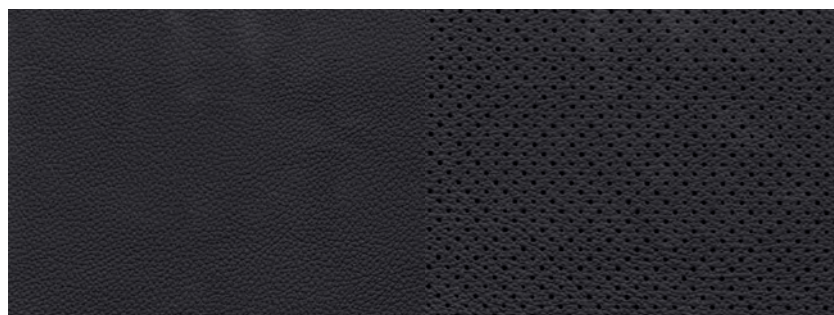

黑色真皮  
Black Leather



15 吋合金輪圈  
15" Alloy Wheels

## 規格表 SPECIFICATIONS

類型 TYPE		IONIQ
尺寸 Dimensions	車身 Exterior	4,470 x 1,820 x 1,450
	長 x 闊 x 高 Length x Width x Height 軸距 Wheel Base (mm)	2,700
引擎 Engine	引擎類型 Engine Variant	Kappa 1.6 Atkinson GDI
	排氣量 Displacement (cc)	1,580
	最大馬力 Max. Power (ps/ rpm)	105/ 5700
	最大扭力 Max. Torque (kg-m/ rpm)	15/ 4000
電動摩打 Electric Motor	類型 Type	永磁同步摩打 Permanent Magnet Synchronous Motor
	最大馬力 Max. Power (ps)	43.5
	最大扭力 Max. Torque (kg-m)	17.3
傳動系統 Transmission		6 前速雙離合器 6 Speed DCT
懸掛系統 Suspension	前 Front	麥花臣式 McPherson Strut Type
	後 Rear	多連桿式 Multi-Link Type
制動系統 Brakes	前 Front	通風碟 Ventilated Discs
	後 Rear	實心碟 Solid Discs
輪胎 Tire		195/65 R15
油缸容量 Fuel Tank (liter)		45

\* 本公司保留改變規格及設備的最終權利，恕不另行通知。  
Hyundai Motor Company and Hyundai Hong Kong Co. Limited reserve the right to change specifications and equipment without prior notice.

\* 本小冊子內容部份設備或非標準配備。  
Some of the equipment illustrated in this catalogue may not be supplied as standard equipment.

\* 基於印刷過程的限制，本小冊子所顯示的顏色與實物顏色或稍有偏差。請向零售商索取內飾和顏色的詳盡資料。  
The color plates shown may vary slightly from the actual colors due to limitations of the printing process. Please consult your dealer for full information and availability on colors and trims.

\* 車輛配備五年或十萬公里的原廠保用，先到者為準。電池保用則為八年（無限公里）。  
5-year or 100,000km factory warranty whichever comes first. 8-year (unlimited mileage) battery warranty.

## 尺寸 DIMENSIONS (mm)



1,549  
1,820

880 | 2,700 | 890  
4,470

1,563